

UNIVERSITY OF CAMBRIDGE INTERNATIONAL EXAMINATIONS
General Certificate of Education
Advanced Subsidiary Level and Advanced Level

GEOGRAPHY

9696/02, 9696/03

Papers 2 and 3

October/November 2005

INSERT

3 hours

READ THESE INSTRUCTIONS FIRST

This insert contains all the Figures referred to in the questions.

Fig.1 for Question 2

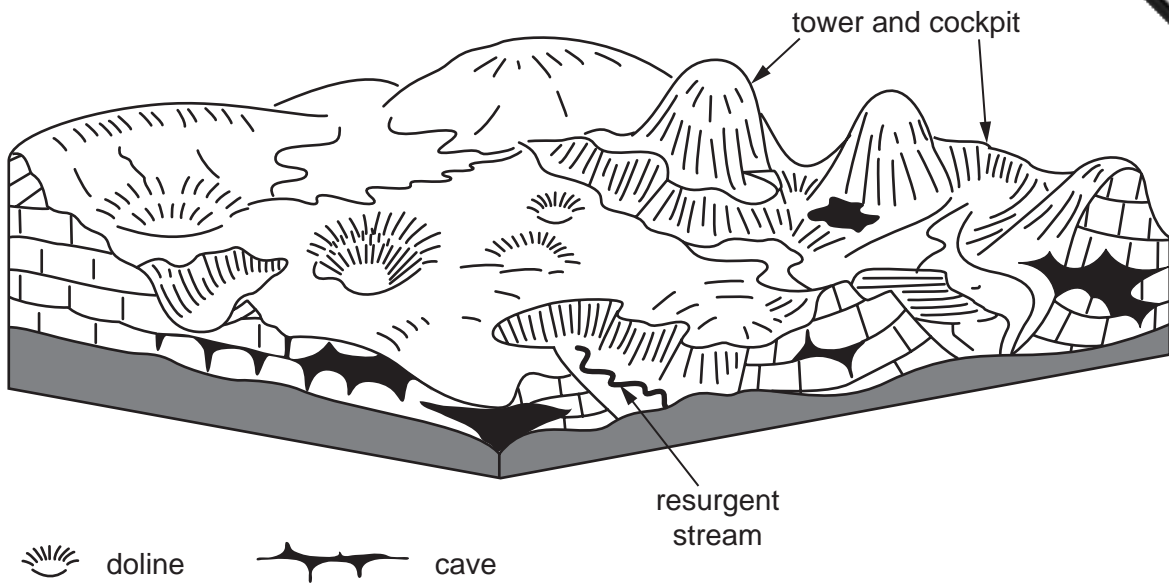

Fig. 2 for Question 4

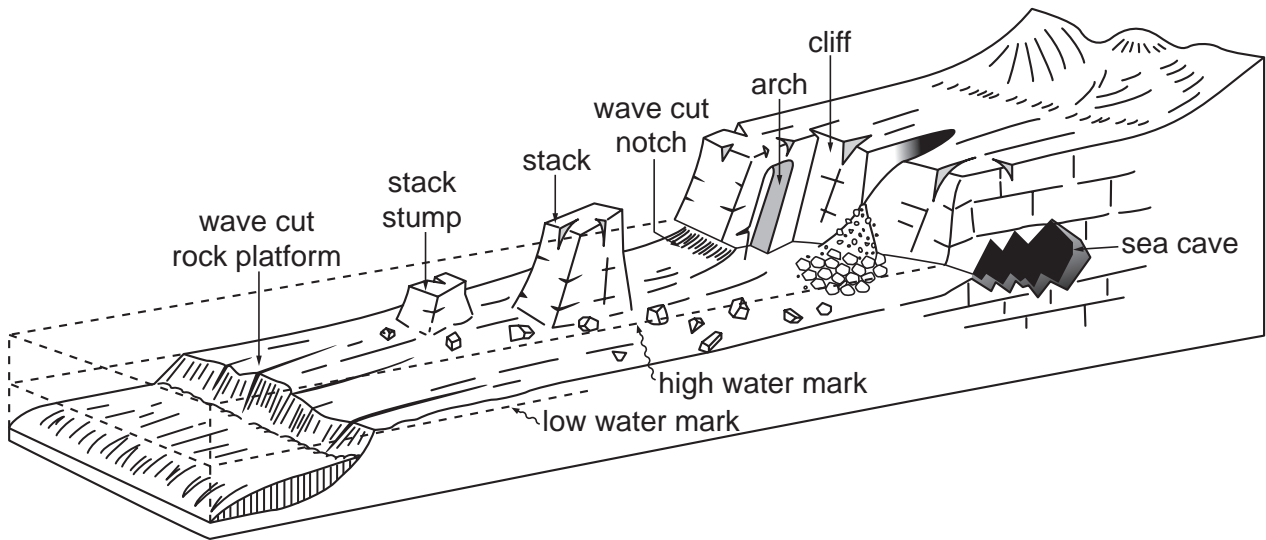

Fig. 3 for Question 6

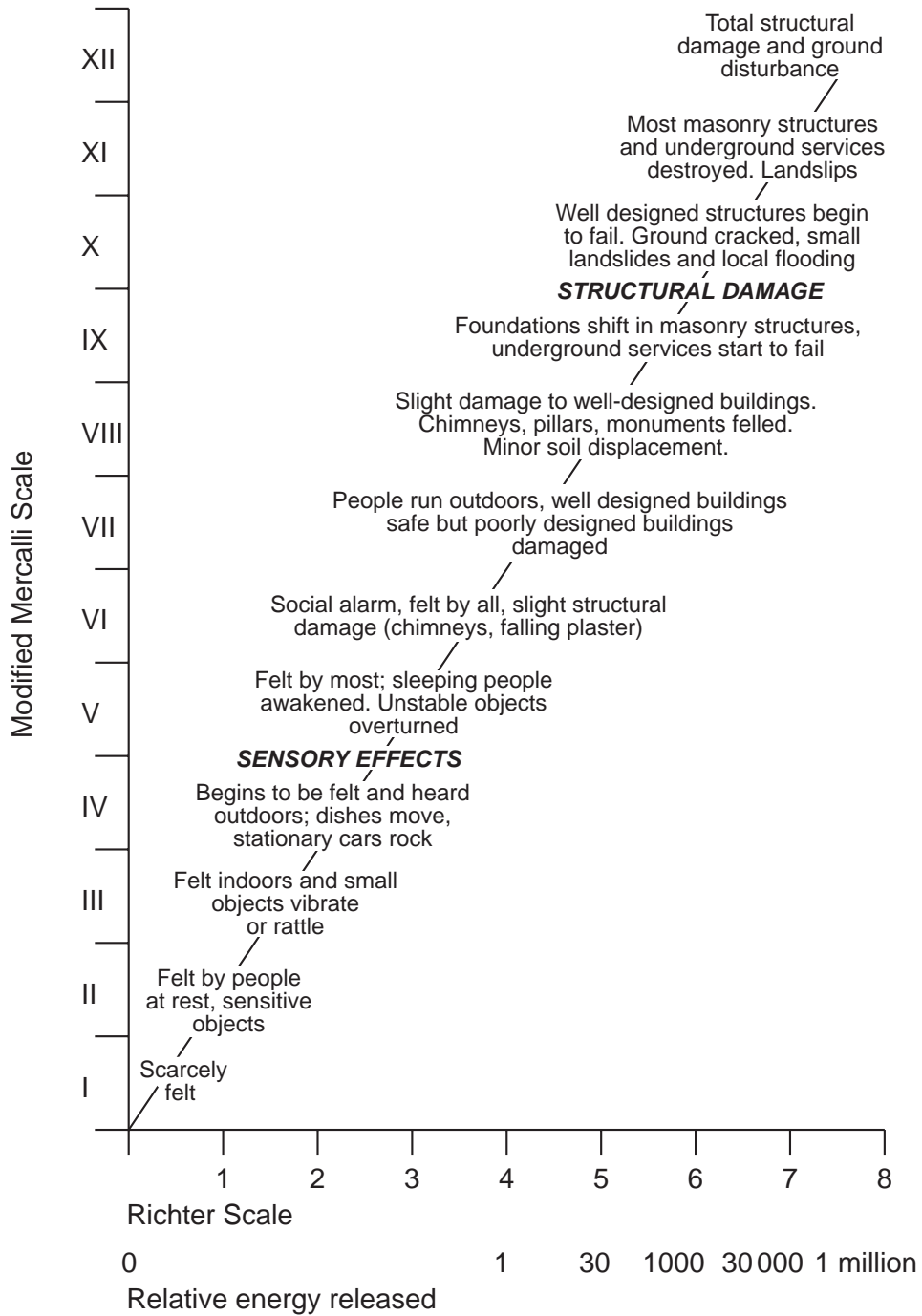

Fig. 4 for Question 8

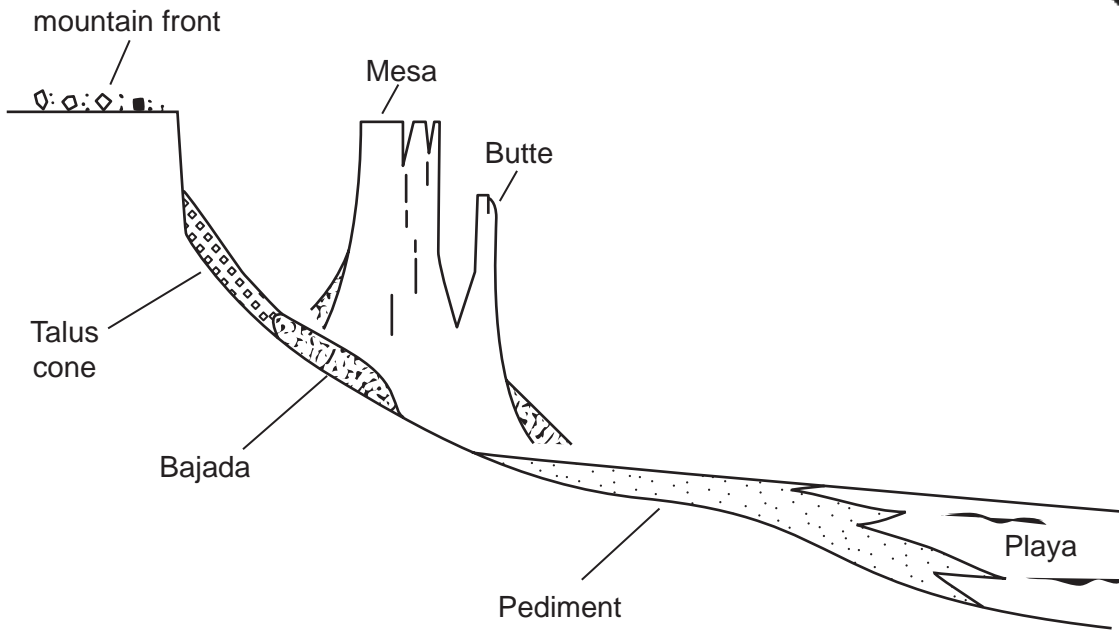

Fig. 5 for Question 9

Changes in the area of agricultural land in China, 1978–96

www.PapaCambridge.com

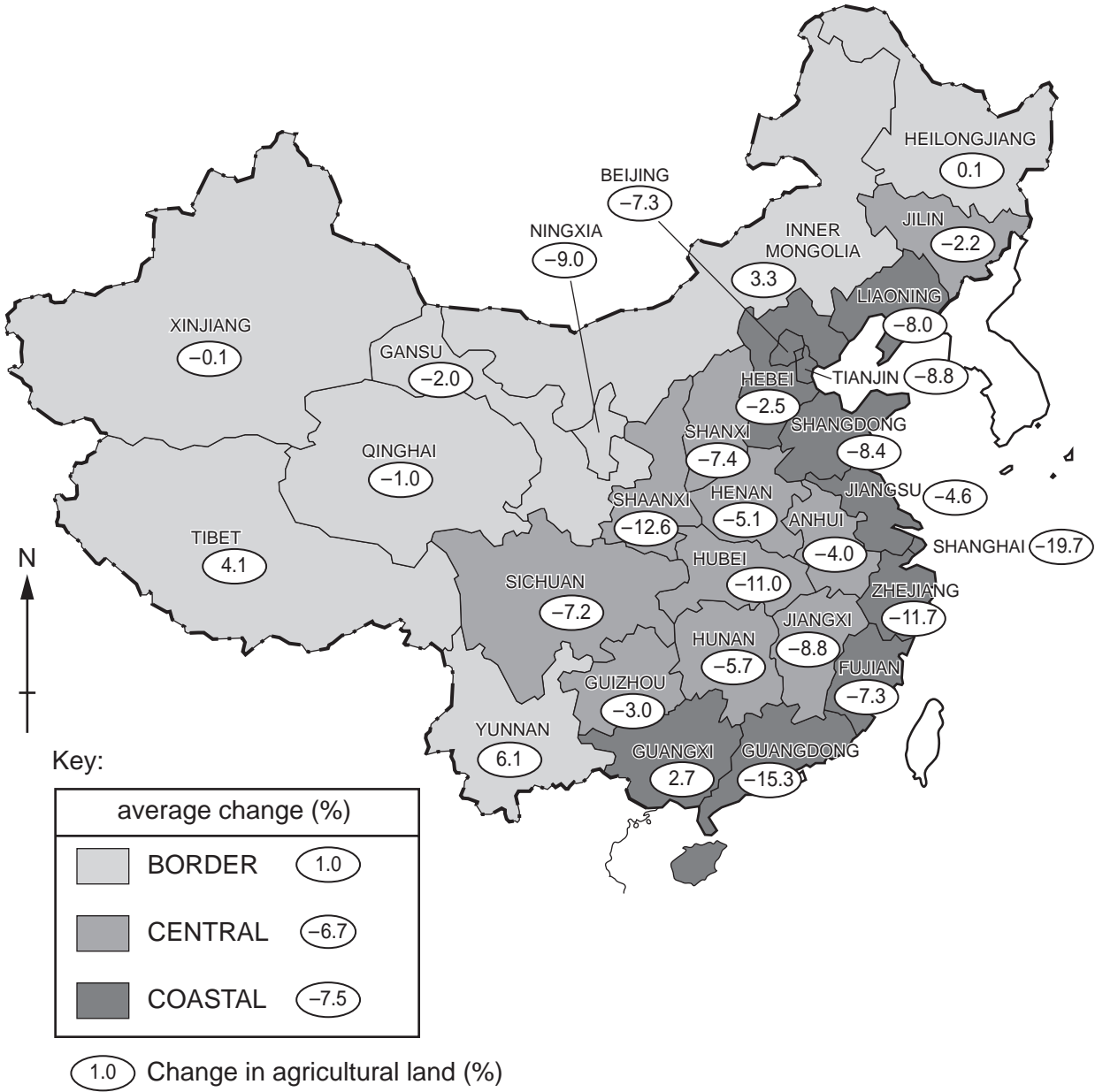
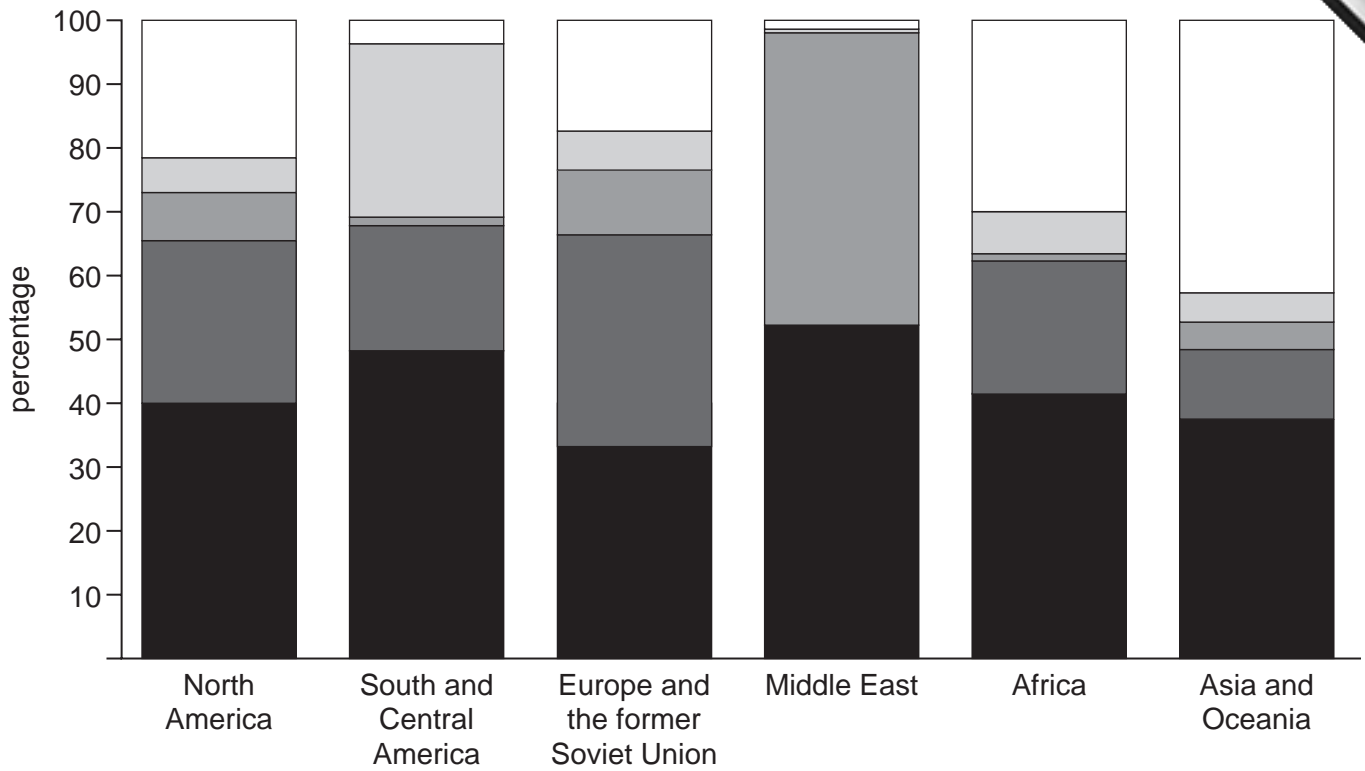

Fig. 6 for Question 11

Energy consumption from different sources for world regions, 2002



Key:

- oil
- natural gas
- nuclear energy
- hydroelectricity
- coal

Fig. 7 for Question 14

State eco-tourism policy and eco-tourism holidays offered in Canada and USA, 199

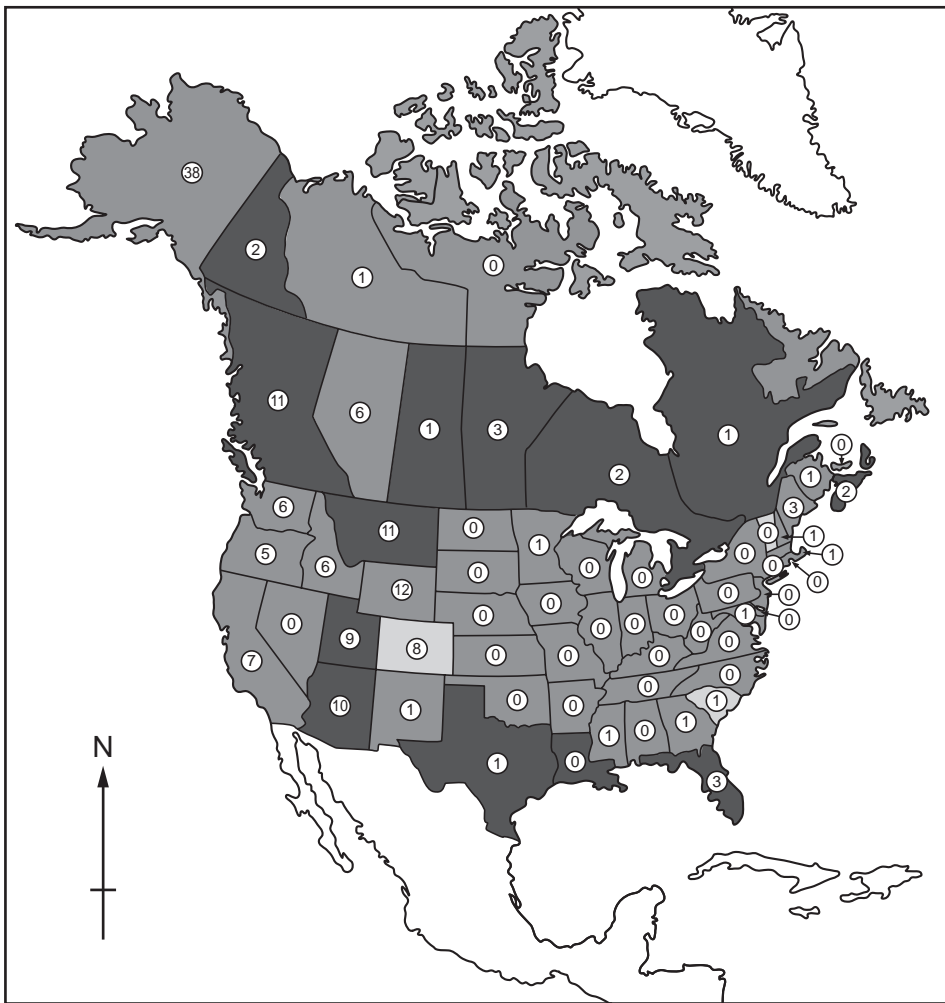

Key:

state eco-tourism policy

■ has a policy

■ no policy

■ unknown

③ number of eco-tourism holidays listed in Special Travel Index

Fig. 8 for Question 15

Social development and economic development of selected countries, 2001

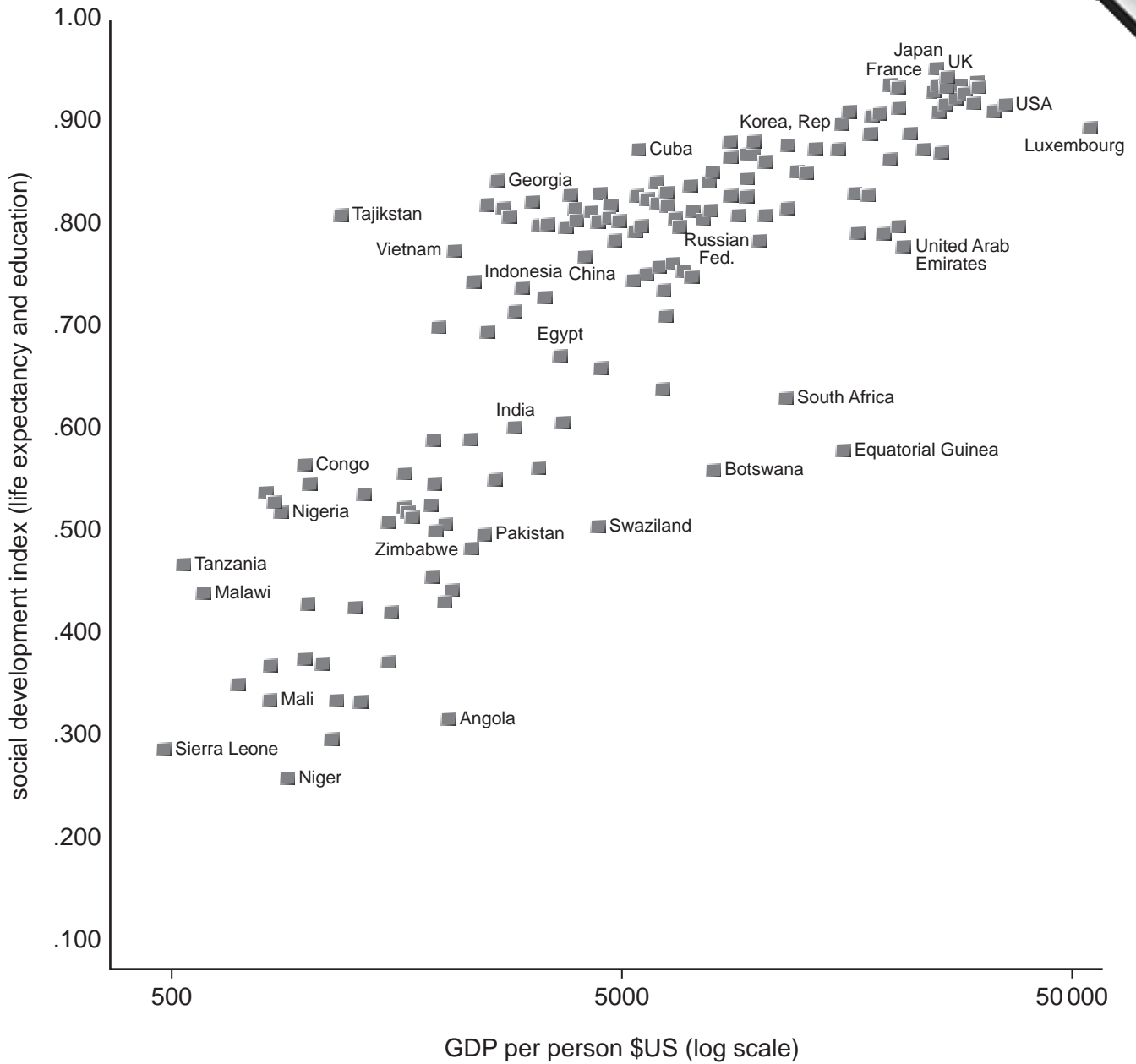

Permission to reproduce items where third-party owned material protected by copyright is included has been sought and cleared where possible. Every reasonable effort has been made by the publisher (UCLES) to trace copyright holders, but if any items requiring clearance have unwittingly been included, the publisher will be pleased to make amends at the earliest possible opportunity.

University of Cambridge International Examinations is part of the University of Cambridge Local Examinations Syndicate (UCLES), which is itself a department of the University of Cambridge.